

PART NUMBER:

OWI-1
OWI-2
OWP-2



Description

Like all OMNTEC sensors, the OWS sensors are easy to install, reliable and cost-effective. The OWS sensors are designed to monitor the accumulation of oil in oil/water separators through the use of one or two floats. Primary features of these oil/water-separator sensors are their versatility and durability. They are designed in segments to allow the user to field-adjust the depth at which the floats will detect oil. This enables the OWS sensors to be used with a variety of tank sizes and site parameters. OMNTEC provides even greater versatility with these sensors by offering the float, mounting and stem in a variety of materials.

The OWI-1 determines the level of the oil/water interface and signals the controller to turn on the audio-visual high-oil-level alarm. The OWI-2 signals both a caution level (warning an operator that the collected-oil level is nearing the pump-out level) and a high-oil level (warning the operator that the OWS has reached the required pump-out level). The OWP-2 monitors the tank for low-liquid levels and can be used for an automatic oil pump-out.

Ruggedly constructed, the OWS sensors provide reliable and cost-effective performance.

Features

- Custom lengths available
- Multiple floats available
- Rugged construction
- Versatile design
- Field adjustable
- Reliable
- Variety of float, mounting and stem materials
- U.L. listed
- Cost-effective
- Modified sensors for special applications

OWI-1

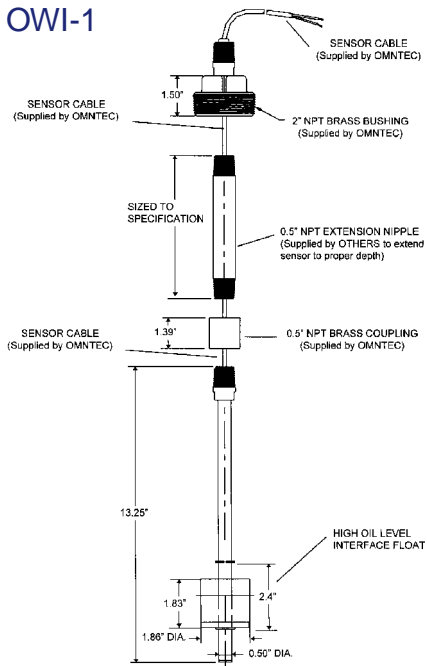

Specifications

Stem and Mounting:	Brass Available in other materials
Float:	Nitrile Available in other materials
Accuracy:	+/- .125 inch
Cable:	PVC jacketed 22 AWG 10 feet supplied OWI-1 2 conductors OWI-2 3 conductors OWP-2 3 conductors
Operating Temperature:	-40 to 180° F
Compatible Controllers:	OEL 8000 For OWI-1, OWI-2 and OWP-2 LU1-OW For OWI-1 LU2-OW For OWI-2 or two OWI-1s LU2-OWP For OWP-2 LU2-OWIR For OWI-1, L-R-1, PDWF, PDWS, PDS LU3-OWIR For OWI-2, L-R-1, PDWF, PDWS, PDS LU3-OWPR For OWP-2, L-R-1, PDWF, PDWS, PDS
Weight:	4 lb.
Approvals:	U.L. listed

Note: Current published specifications are subject to change without notification. Verify specifications with manufacturer.

OWI-2

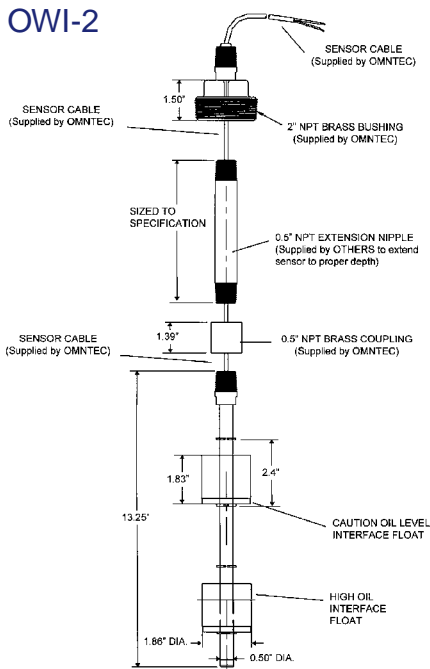

OWP-2

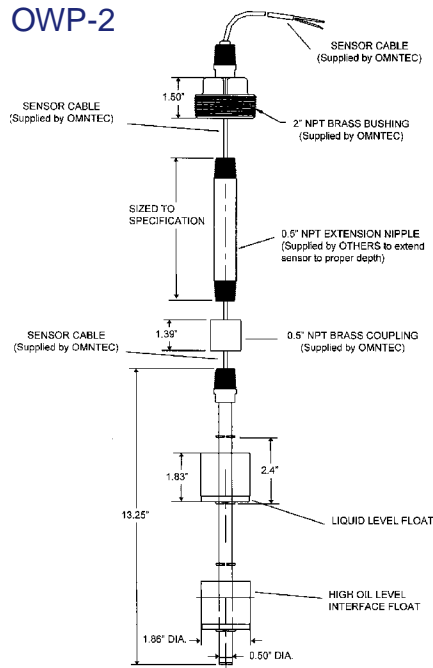

For technical information:



OMNTEC Mfg., Inc.
1993 Pond Road
Ronkonkoma, New York 11779
Phone: 631-981-2001
Fax: 631-981-2007
Email: omntec@omntec.com
Web Site: www.omntec.com
Doc. ows