

OIL WATER SEPARATOR ALARM CONSOLE



SPECIFICATIONS

POWER INPUT

85-125 VAC, 47-440 Hz
16 Watts maximum

POWER TO SENSORS

13.80 VDC @ 13 ma

RELAY OUTPUT

SPST normally open dry contacts 1.25 AMPS, 120 AC/DC switches when an alarm condition occurs

WEIGHT

6 LBS.

ENCLOSURE

NEMA 4X

DIMENSIONS

(W) 9" x (H) 10.5"

SENSOR CABLE

Shielded 22 AWG UL-E118830 CM
Maximum length 2000 feet

ENCLOSURE

NEMA 4X

OPERATING TEMPERATURE

-40° to 140° F

UL LISTED

Intrinsically safe circuits for use in class I group D hazardous locations when connected in accordance with control drawing LU2OW

AUDIO/VISUAL CONSOLE

AUDIBLE ALARM - 95 dB pulsing horn with no timeout
HI OIL LIGHT -Indicates oil has accumulated below the hi oil interface float or the tank liquid level is below the hi oil interface float

CAUTION OIL LIGHT - indicates oil has accumulated below the caution oil interface float or the tank liquid level is below the caution oil interface float

TEST BUTTON- When pressed will actually test system electronics

GREEN LIGHT- indicates the power is on

HORN OFF BUTTON - Silences the audible alarm when pressed

SENSORS

OWI-2 Two point oil/water interface float sensor

ACCESSORIES

RA-1 audio/visual remote annunciator

RLY-RA Relay (consult factory)

RA-1-NYS Remote annunciator with strobe (consult factory)

LABELS

Provided with controller

ELP21LU2-OW

CONTROLLER CONNECTION DIAGRAM

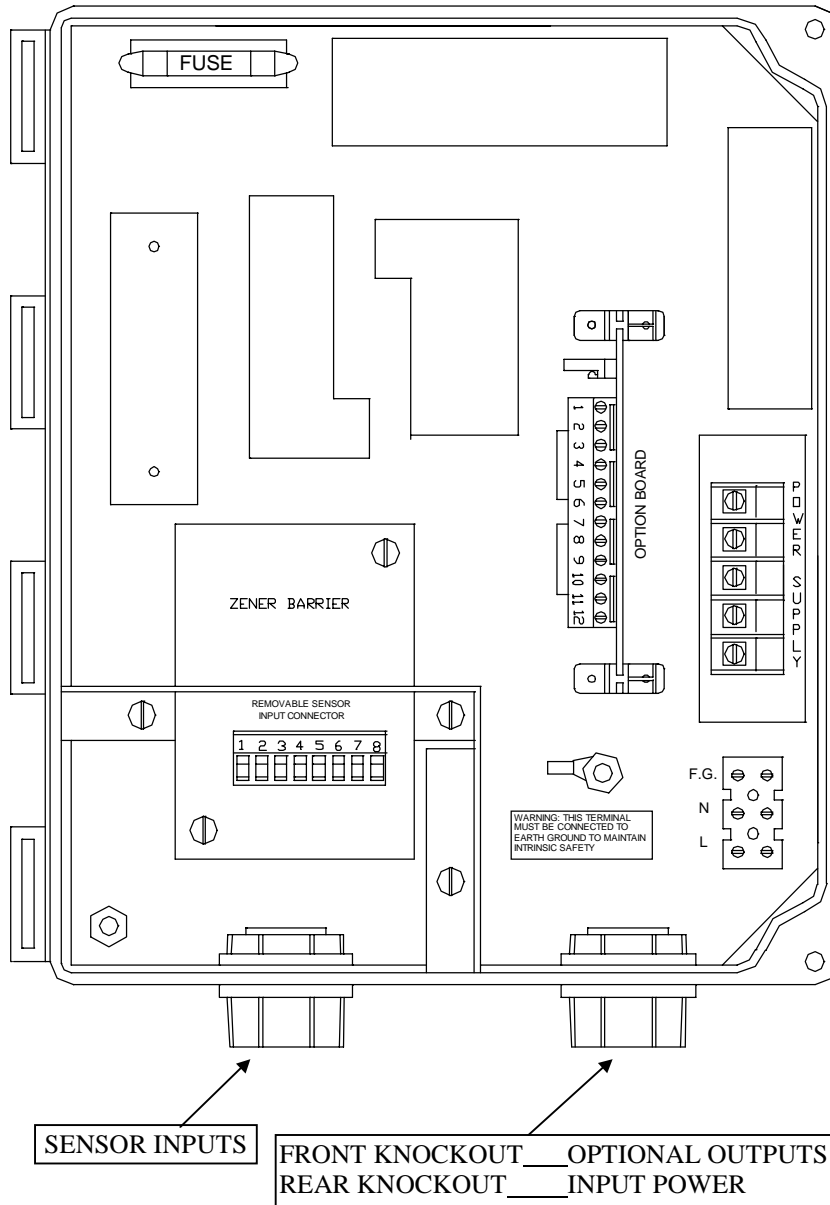

COLOR CODE

CABLES FROM SENSORS TO REMOVABLE SENSOR INPUT CONNECTORS

1	RED	SENSOR #1
2	WHITE	OWI-2
3	UNUSED	
4	UNUSED	
5	UNUSED	
6	UNUSED	
7	BLACK	FROM SENSOR #1
8	SHIELD DRAIN	FROM SENSOR #1

WIRES TO OPTION BOARD

WIRES FROM RA-SERIES REMOTE

1	GREEN	-HORN
2	RED	+HORN
3	BLACK	GROUND
4	WHITE	HIGH OIL LEVEL
5	ORANGE	CAUTION OIL LEVEL
6	UNUSED	

WIRES FROM RELAY OUTPUTS

7	UNUSED	
8	UNUSED	
9	COMMON	CAUTION OIL LEVEL
10	NORMALLY OPEN	
11	COMMON	HIGH OIL LEVEL
12	NORMALLY OPEN	

120VAC

WIRES TO POWER SUPPLY

F.G.	FIELD GROUND
L	LINE
N	NEUTRAL

NOTE: To maintain proper shielding, BLACK sensor wires and SHIELD DRAINS should **not** be connected together at sensors.

ELP21LU2-OW SYSTEM CONTROL DRAWING

POTENTIALLY FLAMMABLE ATMOSPHERE

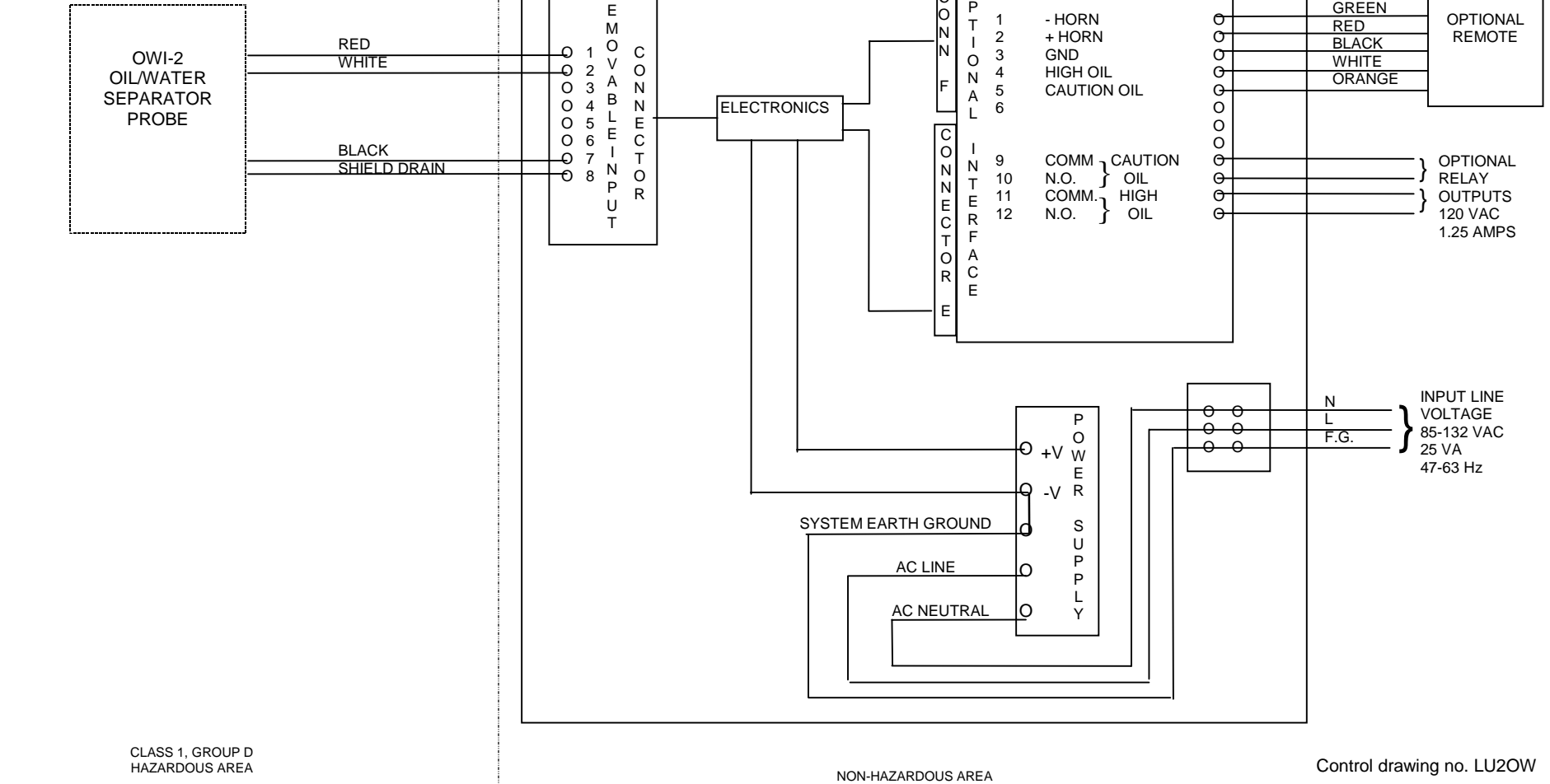

NOTES ON PROBES

1. THE INTRINSICALLY SAFE FIELD WIRING SHALL BE INSTALLED IN ACCORDANCE WITH ARTICLE 504 IN THE NATIONAL ELECTRICAL CODE ANSI/NFPA 70
2. ALL PROBES ARE ELECTRICALLY IDENTICAL AND MAY BE INTERCHANGED ALLOWING SYSTEM FLEXIBILITY
3. PROBE TO CONTROL UNIT CABLE WILL BE TWO PAIR OF #22 AWG WITH SHIELD AND DRAIN PVC JACKETED UL-118830 CM. CABLE LENGTH WILL BE LIMITED TO 2000 FEET MAXIMUM

NOTES ON CONTROL EQUIPMENT

1. ALL WIRING MUST MEET LOCAL AND NATIONAL ELECTRICAL CODES
2. SYSTEM EARTH GROUND MUST BE CONNECTED TO TERMINAL F.G. TO INSURE INTRINSIC SAFETY AND MUST BE LESS THEN 1Ω WITH RESPECT TO EARTH GROUND
3. OPTIONAL REMOTE REQUIRES #22 AWG LOW VOLTAGE COMMUNICATION CABLE MINIMUM

RA-Series Remote High Level Alarm

RA-1

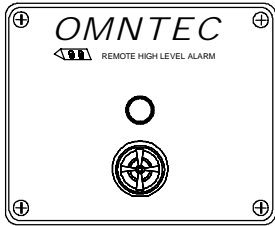

RA-2

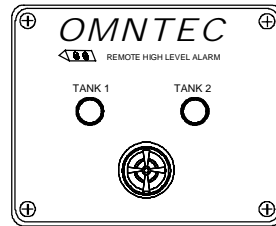

RA-3

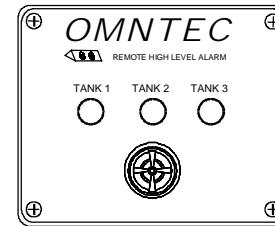

RA-4

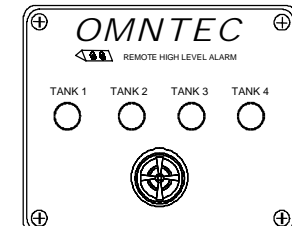

INTERNAL WIRING COLOR CODE

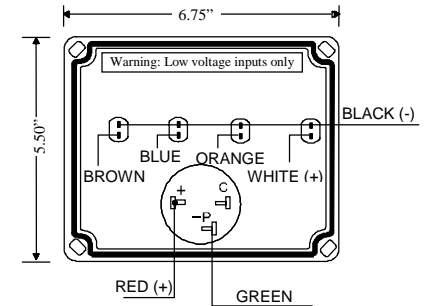
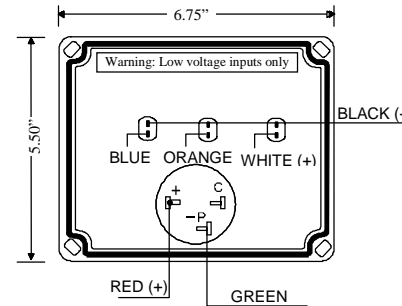
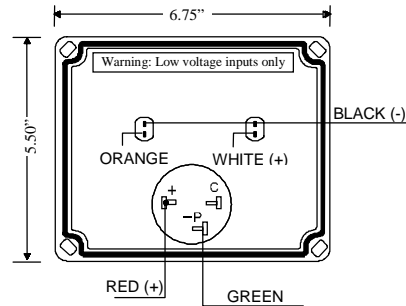
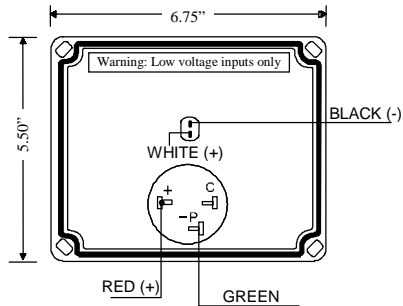

SIDE VIEW

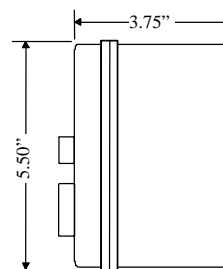

MOUNTING DIMENSIONS

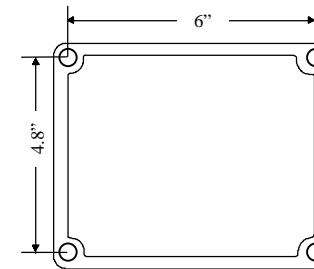

SPECIFICATIONS

Audible Alarm	95 dB pulsing horn
Red Light	Liquid-high-level alarm
Response Time	Immediate
Power Input	12VDC @200mA maximum from controller
Wire	22 AWG minimum
Weight	1 lb.

Note:
It is recommended
that knockouts be
placed in the
bottom of the
enclosure

OWI-2 OIL WATER SEPARATOR

TYPICAL MANWAY EXTENSION BRACKET INSTALLATION

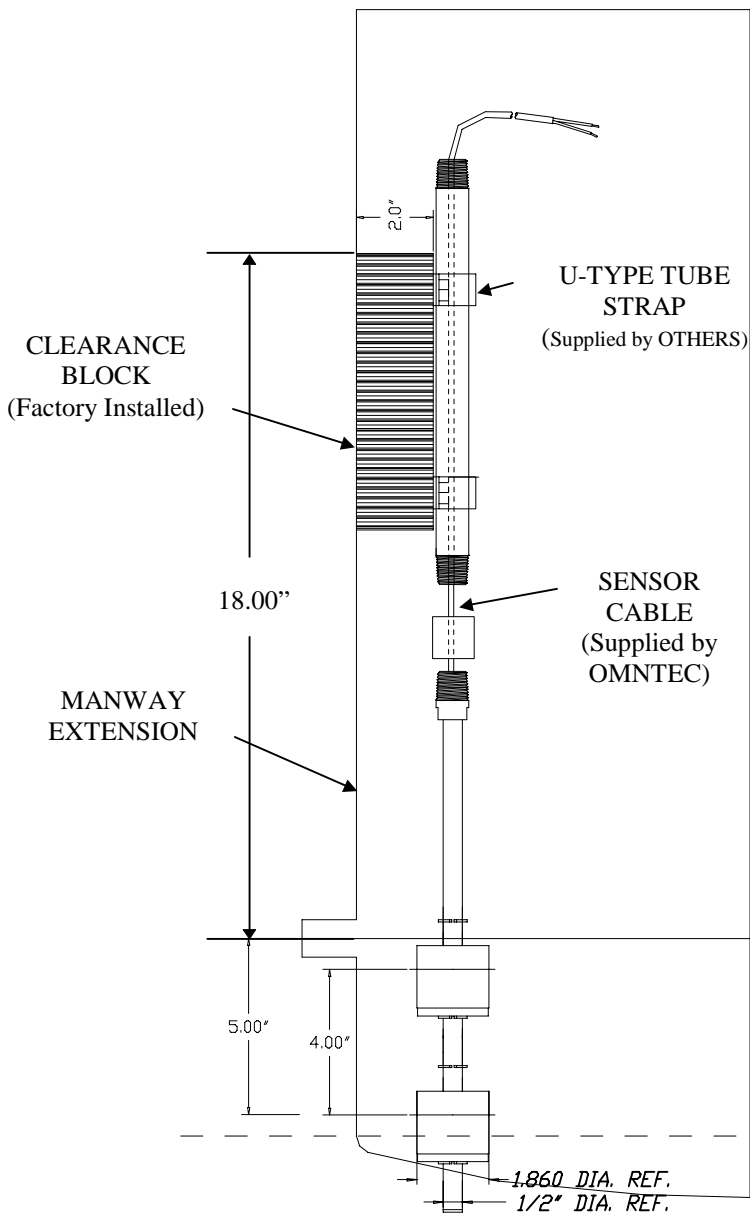

SIDE VIEW

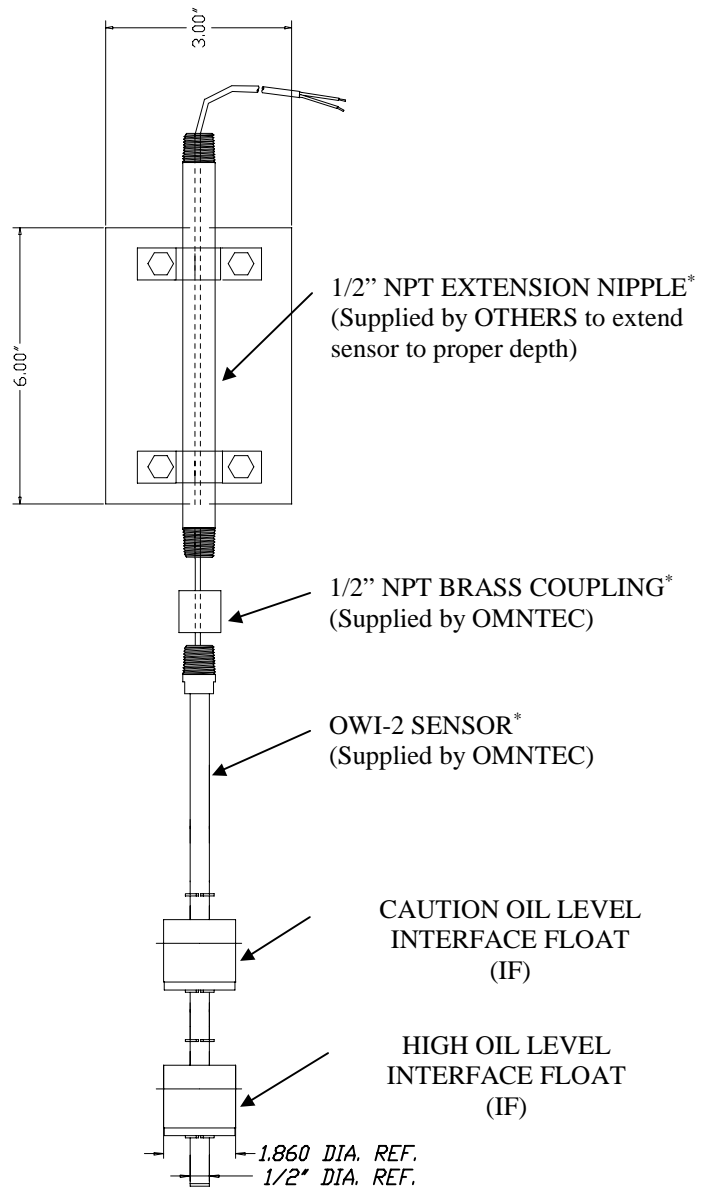

FRONT VIEW

* **WARNING-** It is the installer's responsibility to select a thread sealant that is compatible with the product being stored and that all NPT fittings are fastened properly to assure liquid tight seal for proper sensor operation.

OWI-2 OIL WATER SEPARATOR

TYPICAL 2" FITTING ASSEMBLY

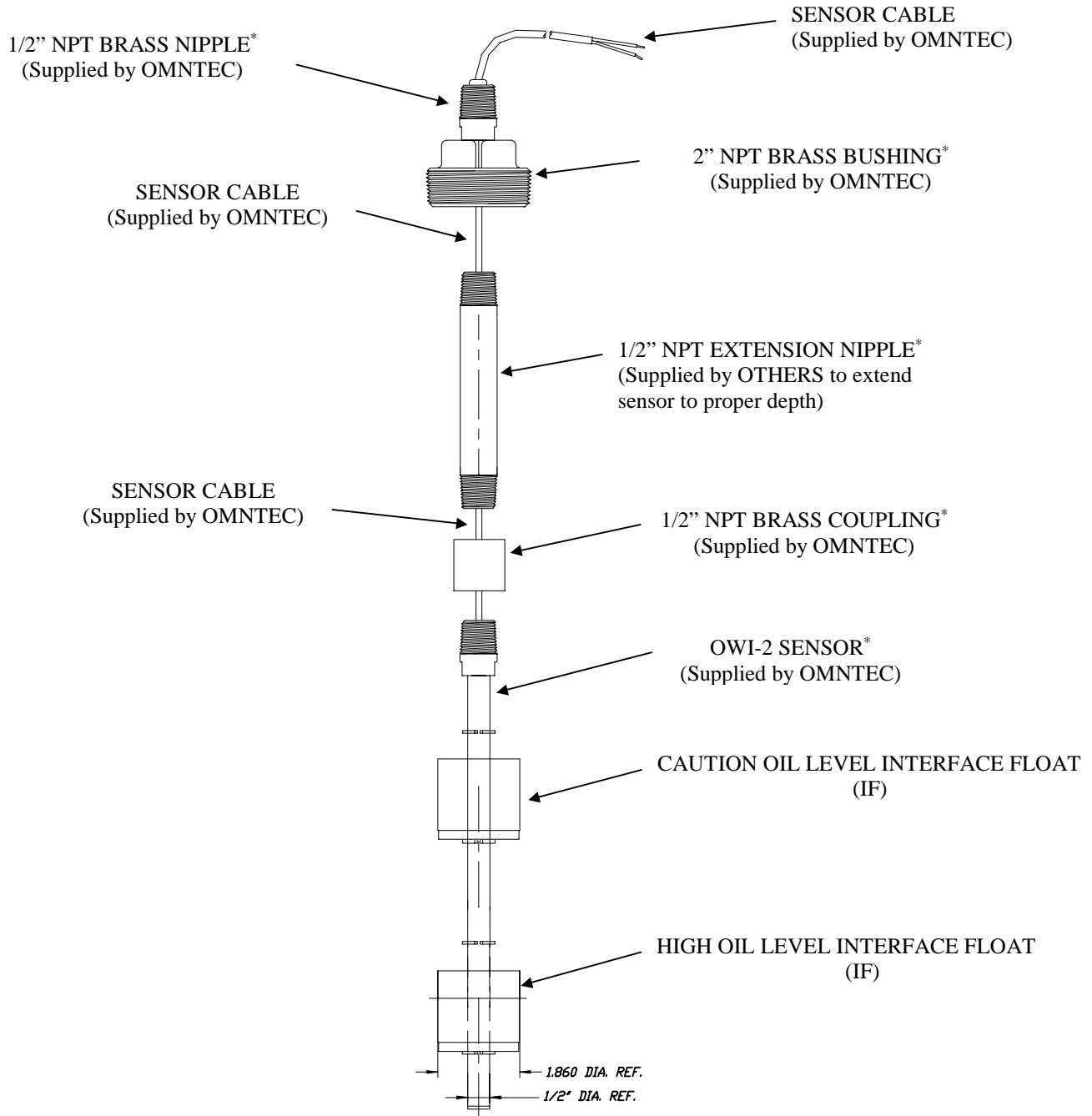

* **WARNING-** It is the installer's responsibility to select a thread sealant that is compatible with the product being stored and that all NPT fittings are fastened properly to assure liquid tight seal for proper sensor operation.

WARRANTY

The seller OMNTEC Mfg., Inc. warrants to buyer, for one year: That all components meet specifications herein. All components are free of defects when properly installed, and maintained by user. The sellers sole obligation is to repair or replace parts found to be defective, or non-conforming after evaluation by factory. The liability of the seller shall not exceed the price paid for the components found to be defective. The above warranty is exclusive of all other warranties whether implied or expressed. Seller assumes no obligation for special or, indirect damages incurred by user.